

Motori Nanni Diesel N3.21 (Base Kubota)

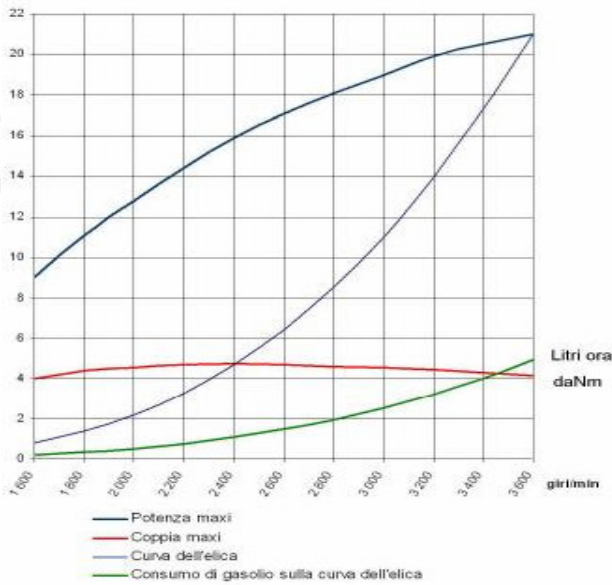

Specifiche tecniche:

Potenza *	15,4 kW (21 cv)
Regime maxi *	3600 giri/min
Cilindrata	0,719 litri (46,86 cu inch)
Numero di cilindri	3 in linea
Alesaggio / corsa	67 mm x 68 mm (2,64" x 2,68")
Rapp.to di compressione	23 / 1
Iniezione	Indiretta (E-TVCS)
Aspirazione	Atmosferica
Raffreddamento	Scambiatore di calore
Alternatore	12 V / 70 A
Pannello strumenti	A3
Invertitore	Meccanico
Angolo installazione maxi	15°
Sail Drive	SD 2,52 : 1
Peso (incluso invertitore)	106 kg (233,7 lbs)
(incluso Sail Drive)	144 kg (317,47 lbs)

Diametri:

Scarico	45 et 50 mm (1,77 et 1,97")
Carburante	8 mm (0,31")
Acqua mare	20 mm (0,79")

*Al volano motore, secondo ISO 8665-1.

- Versione linea d'asse -

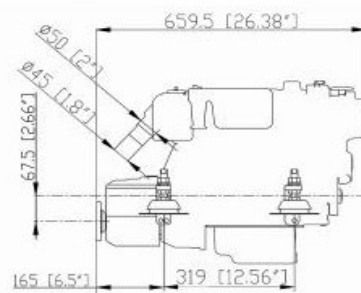
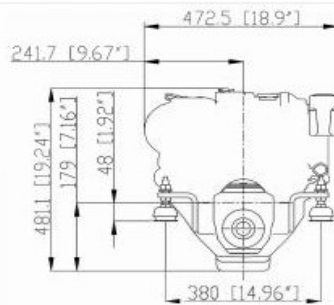

N3.21 + TMC 40

- Versione Sail Drive -

